



T0010502 CHEST PRESS INCLUSIVE

T0010502 CHEST PRESS INCLUSIVE

VISTA TRIDIMENSIONALE

THREE-DIMENSIONAL VIEW

SCHEDA TECNICA (TECHNICAL DATA SHEET)

ART. T0010502

06-06-2024

SCALA (SCALE)

LE MISURE SONO ESPRESSE IN MM. (MEASUREMENTS ARE EXPRESSED IN MM.)



TIEGI SRL
 VIA BENEDETTO CROCE 7,
 Z.I. "CONDOTTI BARDINI",
 31058 SUSEGANA (TV)
 0438-460519

FOGLIO 1 DI 5

PIANTA (PLAN)

5020

3710

710

2030

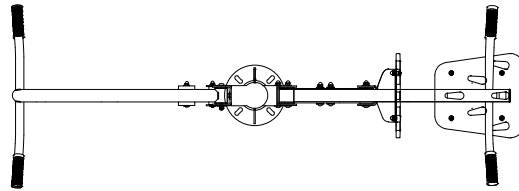

AREA DI SICUREZZA (SECURITY AREA) 19 MQ

SCHEDA TECNICA (TECHNICAL DATA SHEET)

ART. T0010502

06-06-2024

SCALA (SCALE) 1:30

LE MISURE SONO ESPRESSE IN MM. (MEASUREMENTS ARE EXPRESSED IN MM.)



TIEGI SRL
VIA BENEDETTO CROCE 7,
Z.I. "CONDOTTI BARDINI",
31058 SUSEGANA (TV)
0438-460519

FOGLIO 2 DI 5



ALTEZZA DI CADUTA MAX.
(MAX. FALL HEIGHT): < 100 cm



INGOMBRO (OVERALL DIMENSION)
203 cm X 71 cm X 201 cm H.



NUMERO UTILIZZATORI 2
(MAX N. OF SIMULTANEOUS USERS)



AREA DI SICUREZZA (SECURITY AREA)
502 cm X 371 cm



SUP. ANTITRAUMA CONSIGLIATA
(RECOMMENDED SAFETY SURFACING AREA)
19 MQ.



ALTEZZA D'USO (HEIGHT USE)
>140 cm

SCHEDA TECNICA (TECHNICAL DATA SHEET)

ART. T0010502

06-06-2024

SCALA (SCALE)

LE MISURE SONO ESPRESSE IN MM. (MEASUREMENTS ARE EXPRESSED IN MM.)



TIEGI SRL
VIA BENEDETTO CROCE 7,
Z.I. "CONDOTTI BARDINI",
31058 SUSEGANA (TV)
0438-460519

FOGLIO 3 DI 5

TUBI IN METALLO CURVATI. PROCESSO DI VERNICIATURA PER CATAFORESI, PRIMER E VERNICIATURA TERMOINDURENTE 180°C
(*CURVED METAL TUBES. CATAPHORESIS, PRIMER AND 180°C THERMOSETTING PAINTING PROCESS APPLIED*)



MANOPOLE ZIGRINATE
(*KNURLED HANDLES*)

L'ATTREZZO È PROVVISORIO DI QR CODE PER LA VISIONE DI VIDEO ESPLICATIVO D'USO (*THE EQUIPMENT IS PROVIDED WITH A QR CODE, DISPLAYING AN EXPLANATORY VIDEO OF THE EXERCISE*)

PIASTRE IN METALLO CON PROCESSO DI VERNICIATURA DI CATAFORESI, PRIMER E VERNICIATURA TERMOINDURENTE 180°C (*METAL PLATES WITH CATAPHORESIS, PRIMER AND 180°C THERMOSETTING PAINTING PROCESS APPLIED*)

TUTTI GLI ELEMENTI DI FISSAGGIO, VITI, DADI, RONDELLE ECC. SONO IN ACCIAIO INOX
(*ALL FASTENERS, SCREWS, NUTS, WASHERS, ETC. ARE MADE OF STAINLESS STEEL*)

SCHEDA TECNICA (TECHNICAL DATA SHEET)

ART. T0010502

06-06-2024

SCALA (SCALE)

LE MISURE SONO ESPRESSE IN MM. (MEASUREMENTS ARE EXPRESSED IN MM.)



TIEGI SRL
VIA BENEDETTO CROCE 7,
Z.I. "CONDOTTI BARDINI",
31058 SUSEGANA (TV)
0438-460519

FOGLIO 4 DI 5

VISTA FRONTALE
(FRONTAL VIEW)

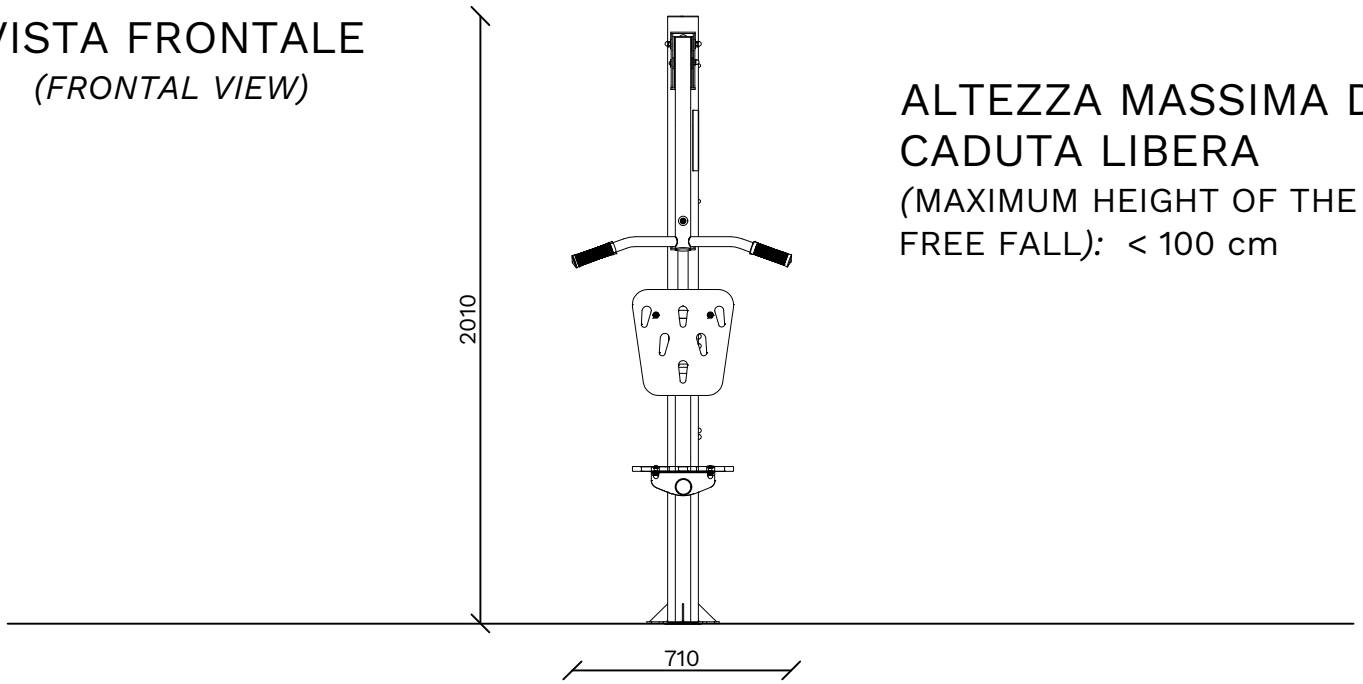

ALTEZZA MASSIMA DI
CADUTA LIBERA
(MAXIMUM HEIGHT OF THE
FREE FALL): < 100 cm

VISTA LATERALE
(LATERAL VIEW)

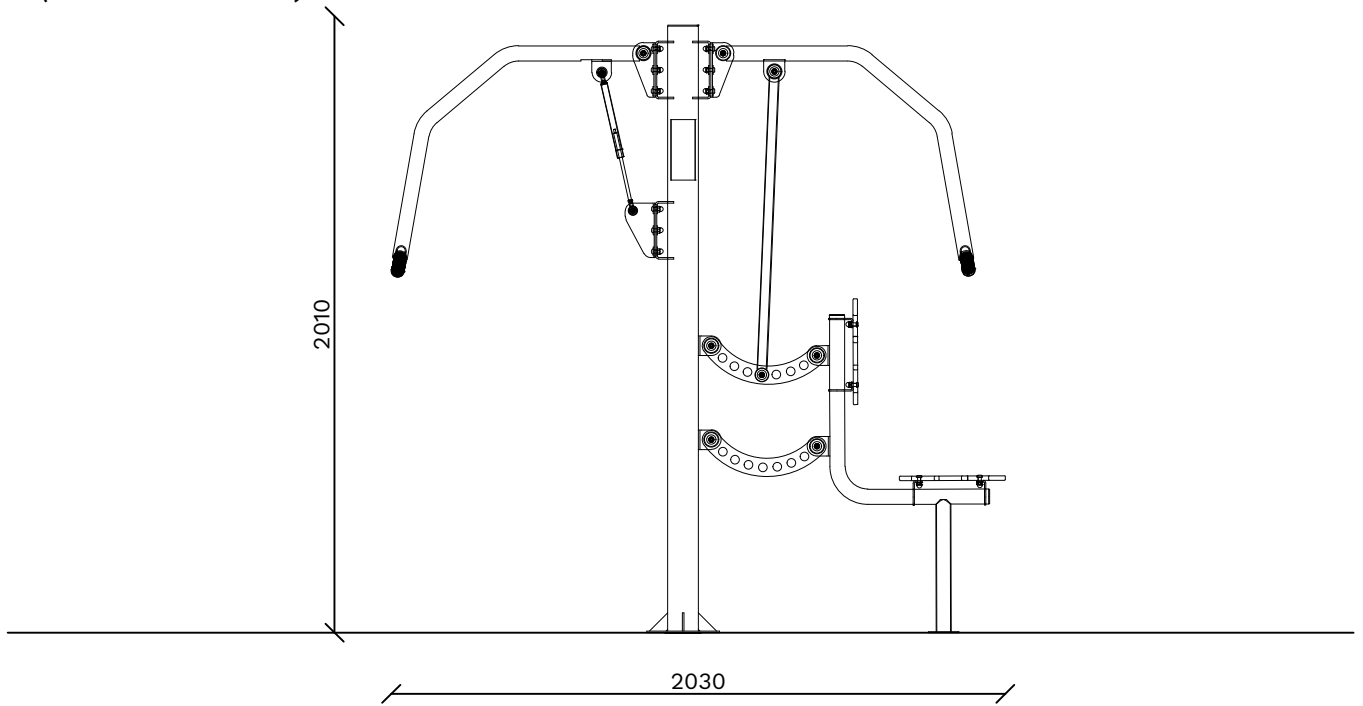

INGOMBRO MAX (OVERALL DIMENSIONS)

SCHEDA TECNICA (TECHNICAL DATA SHEET)

ART. T0010502

06-06-2024

SCALA (SCALE) 1:25

LE MISURE SONO ESPRESSE IN MM. (MEASUREMENTS ARE EXPRESSED IN MM.)



TIEGI SRL
VIA BENEDETTO CROCE 7,
Z.I. "CONDOTTI BARDINI",
31058 SUSEGANA (TV)
0438-460519

FOGLIO 5 DI 5